



The Thermoelectric Valve Drive is used to open and close valves in Heating, Ventilating and Air-Conditioning (HVAC) systems.

The device can be controlled (2-point output or pulse width modulation) with the Electronic Switch Actuator ES/S or with the Electronic Relay ER/U in combination with the Universal Interface US/U and a Room Thermostat.

The snap-on mounting on valves or in heating circuit distributors will be established by Valve Adapters VA/Z.

Technical Data

Version	Normally Closed First-Open function	NC Enables heating operation during the carcass construction phase even when the electric wiring of the single room control is not yet complete.
Power supply	Operating Voltage Operating current Max. inrush current Operating power Over voltage protection according to EN 60730-1	230 V AC \pm 10%, 50/60 Hz 8 mA 300 mA during 200 ms max. 1.8 W At least 2.5 kV
Connection	Connection cable (pluggable) Length	2 x 0.75 mm ² , light grey 1 m
Operating and display elements	Function display	Displays whether the valve is opened or closed
Valve drive mechanic	Actuator travel Actuator force Closing and opening times	4 mm 100 N \pm 5% Approx. 3 min.
Ambient temperature range	Fluid Environment Storage	0 °C ... + 100 °C 0 °C ... + 60 °C - 25 °C ... + 60 °C
Design	Compact device for placing on valve bases	
Housing	Dimensions (H x W x D) Material Colour Anti-theft device	60 x 44 x 61 mm Plastic White, RAL 9003 Removable clip
Montage	Snap-on mounting Installation positions	Via Valve Adapter VA/Z 360° (vertical and horizontal recommended)
Type of protection	IP 54 (in all installation positions)	According to DIN EN 60529
Protection class	II	According to DIN EN 61140
Weight	0.1 kg	
CE-norm	According to EN 60730	

Accessory

Type	Model
VA/Z 10.1	Valve Adapter (M 30 x 1.5) for Dumser, Chronatherm, Vescal, KaMo
VA/Z 50.1	Valve Adapter (M 30 x 1.5) for Honeywell, Reich, Cazzaniga, Landis & Gyr., MNG
VA/Z 78.1	Valve Adapter (Flange) for Danfoss RA
VA/Z 80.1	Valve Adapter (M 30 x 1.5) for Heimeier, Herb, Onda, Schlösser (from 93), Oventrop

Circuit diagram

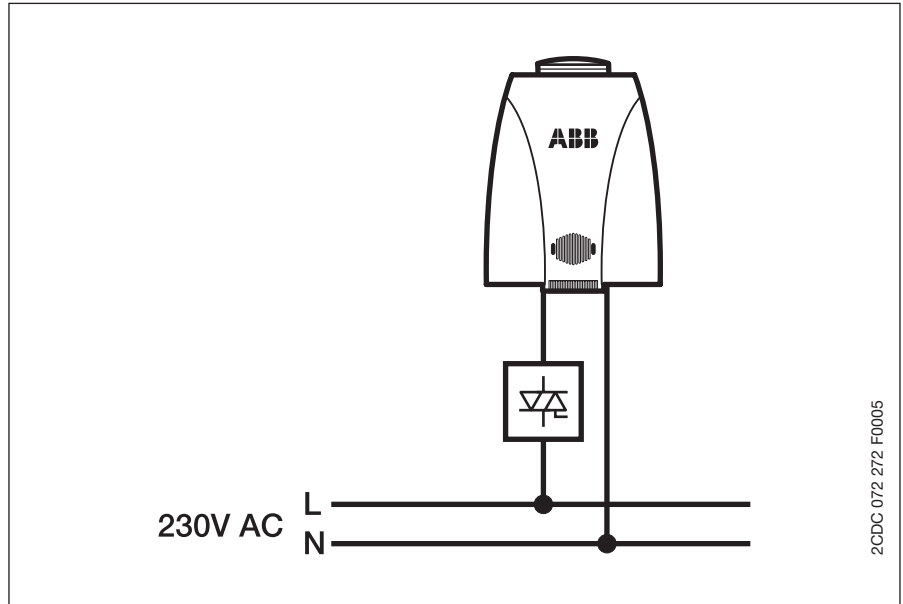

Dimension drawing

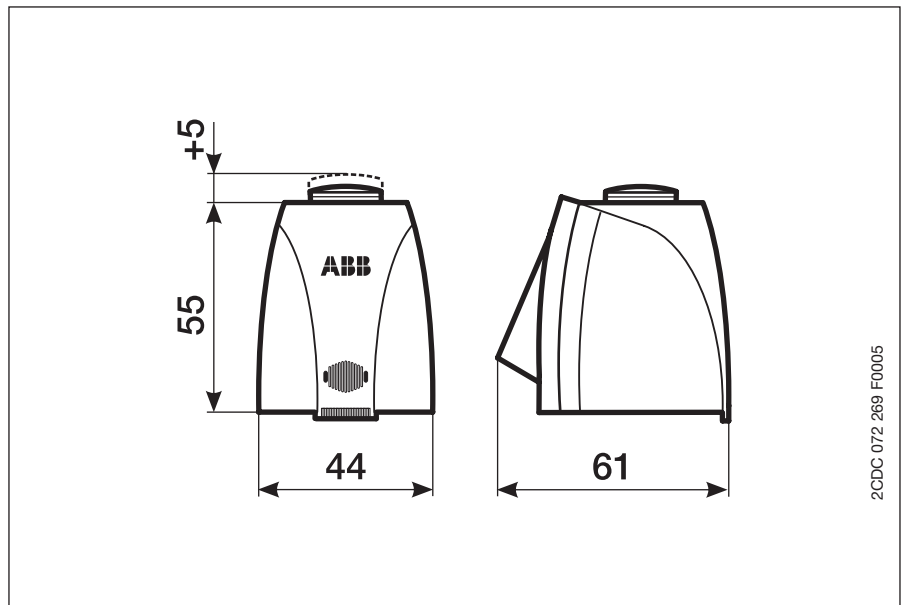

Characteristic curves

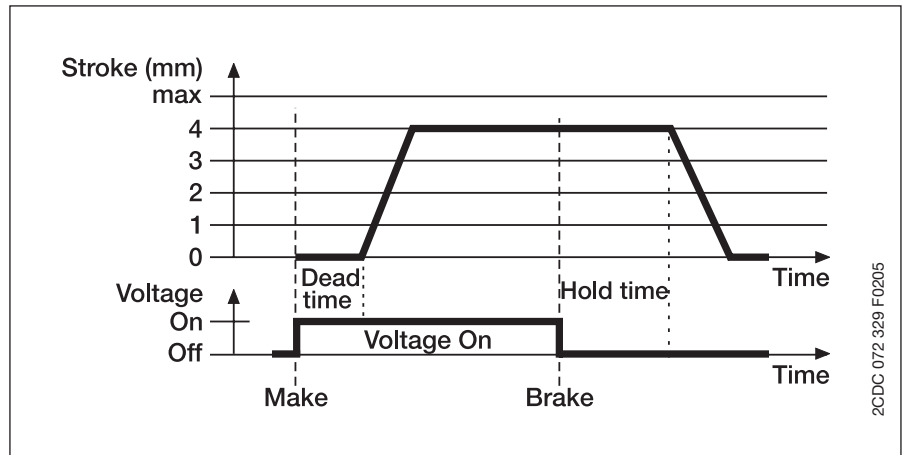

Mounting and Installation

Generally all installation positions are possible for practical use. Preferred installation positions of the valve drive are vertical and horizontal. An upside-down position may reduce product life through special circumstances (e.g. contaminated water).

The valve adaptation occurs via the Valve Adapter VA/Z. Those are available for the most common valve bases and heating circuit distributors.
See also **Accessory**.

In its delivery state the valve drive is normally open due to the First-Open function. This enables heating operation during the carcass construction phase even when the electric wiring of the single room control is not yet complete. When commissioning the system at a later date, the First-Open function is automatically unlocked by applying the operating voltage (> 6 min.) and the valve drive is fully operable.

We recommend the following wires for installation a 230 V system:

Light plastic-sheated cable:	NYM	1.5 mm ²
Flat webbed building wire:	NYIF	1.5 mm ²

Important notes



Installation and commissioning of the device may only be carried out by trained electricians. The relevant standards, directives, regulations and instructions must be observed when planning and implementing the electrical installation.

Protect the device against moisture, dirt and damage during transport, storage and operation!

Do not operate the device outside the specified technical data (e.g. Temperature range)!

Cleaning

Should the device become soiled, it may be cleaned with a dry cloth. If this does not suffice, a cloth lightly moistened with soap solution may be used. On no account should caustic agents or solvents be used.

Maintenance

The device is maintenance free. Should damage have occurred, e.g. due to transport or storage, no repairs should be carried out.

The warranty expires if the device is opened!

